

M81935/5 SELF-LUBRICATED ROD END BEARINGS

AS81935/5 • AS81935 (formerly MIL-B-81935)

- Female type, rod end
- High temperature — low wear
-65°F to +325°F (-53.9°C to +162.8°C)
- Material: Bearing inner ring: CRES 440C
Bearing outer ring: CRES 17-4PH
Rod end housing: AISI 4340 steel heat treated to 180,000 psi min. tensile strength. Exposed surface of rod end housing cadmium plated
- Liner: Fibriloid® or “E” Uniflon® qualified to AS81820
- Threads conform to UNJF-3B per AS8879. For left hand thread add “L” or “1” depending on part number ordered. Example: see below
- For rod end with keyway in end of shank add “K” or “1” Example: see below
- For rod end with deep key slot on base add “W” Example: see below

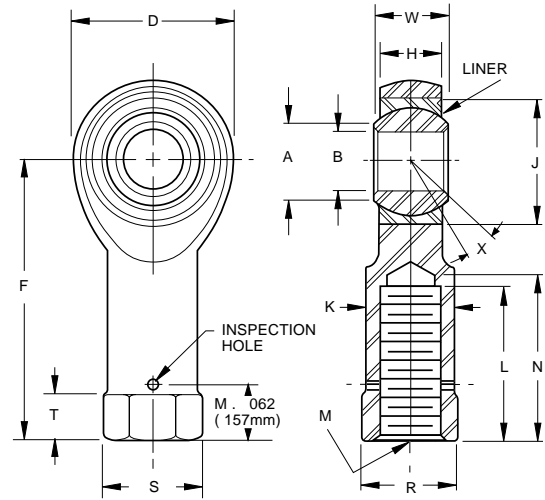

SPECIFICATIONS AND ORDERING INFORMATION

DIMENSIONS — TOLERANCES

PART NUMBERS FE-AN Dash No.	M81935/5 Dash No.	B		D		L ⁽¹⁾		F		K		W		H		A		J		N		S ⁽²⁾		T		R ⁽¹⁾		M		X°
		in.	mm	in.	mm	in.	mm	in.	mm	in.	mm	in.	mm	in.	mm	in.	mm	in.	mm	in.	mm	in.	mm	in.	mm	in.	mm	in.	mm	
03	-03	.1900	4.826	0.680	17.27	0.625	15.88	1.210	30.73	.329	8.36	.281	7.14	0.228	5.79	0.293	7.44	.5625	14.29	.750	19.05	.430	10.92	.188	4.78	.375	9.53	1/4-28	10	
04	-04	.2500	6.350	0.827	21.01	0.625	15.88	1.338	33.99	.329	8.36	.343	8.71	0.260	6.60	0.364	9.25	.6562	16.67	.750	19.05	.430	10.92	.188	4.78	.375	9.53	1/4-28	10	
05	-05	.3125	7.938	0.984	24.99	0.750	19.05	1.566	39.78	.413	10.49	.375	9.53	0.291	7.39	0.419	10.64	.7500	19.05	.875	22.23	.500	12.70	.188	4.78	.437	11.10	5/16-24	10	
06	-06	.3750	9.525	1.131	28.73	1.000	25.40	1.908	48.46	.501	12.73	.406	10.31	0.322	8.18	0.475	12.07	.8125	20.64	1.125	28.58	.720	18.29	.250	6.35	.625	15.88	3/8-24	9	
07	-07	.4375	11.113	1.294	32.87	1.125	28.58	2.125	53.98	.584	14.83	.437	11.10	0.353	8.97	0.530	13.46	.9062	23.02	1.250	31.75	.720	18.29	.250	6.35	.625	15.88	7/16-20	8	
08	-08	.5000	12.700	1.459	37.06	1.250	31.75	2.356	59.84	.672	17.07	.500	12.70	0.400	10.16	0.600	15.24	1.0000	25.40	1.375	34.93	1.020	25.91	.375	9.53	0.875	22.23	1/2-20	8	
10	-10	.6250	15.875	1.763	44.78	1.375	34.93	2.707	68.76	.845	21.46	.625	15.88	0.510	12.95	0.739	18.77	1.1875	30.16	1.500	38.10	1.020	25.91	.375	9.53	0.875	22.23	5/8-18	8	
12	-12	.7500	19.050	2.140	54.36	1.625	41.28	3.193	81.10	1.017	25.83	.750	19.05	0.603	15.32	0.920	23.37	1.4375	36.51	1.750	44.45	1.300	33.02	.500	12.70	1.125	28.58	3/4-16	8	
14	-14	.8750	22.225	2.372	60.25	1.875	47.63	3.677	93.40	1.187	30.15	.875	22.23	0.713	18.11	0.980	24.89	1.5625	39.69	2.062	52.37	1.375	34.93	.500	12.70	1.250	31.75	7/8-14	8	
16	-16	1.0000	25.400	2.681	68.10	2.125	53.98	4.101	104.17	1.356	34.44	1.000	25.40	0.807	20.50	1.118	28.40	1.7500	44.45	2.312	58.72	1.590	40.39	.500	12.70	1.375	34.93	1-12	9	

⁽¹⁾Completed thread.

⁽²⁾Measured across corners or diameter.

LOAD RATINGS

PART NUMBERS FE-AN Dash No.	M81935/5 Dash No.	Ultimate Static Radial Load		Fatigue Load		Axial Proof Load		Approx. Weight		No Load Rational Breakaway Torque			
		lb.	N	lb.	N	lb.	N	lbs.	kg	in.-lbs.	Nm	in.-lbs.	Nm
03	-03	3000	13320	1100	4884	150	666	0.044	0.020	0.5	0.06	6	0.68
04	-04	5500	24420	1300	5772	430	1909	0.052	0.024	0.5	0.06	6	0.68
05	-05	8900	39516	2000	8880	700	1108	0.087	0.040	1	0.11	15	1.70
06	-06	13400	59496	3100	11764	1100	4884	0.137	0.062	1	0.11	15	1.70
07	-07	18200	80808	4200	18648	1400	6216	0.193	0.088	1	0.11	15	1.70
08	-08	24600	109224	5700	25308	1040	9058	0.279	0.127	1	0.11	15	1.70
10	-10	39500	175380	9200	40848	1430	10789	0.504	0.229	1	0.11	15	1.70
12	-12	57200	253968	11500	59940	1940	11054	0.860	0.391	1	0.11	15	1.70
14	-14	77800	345432	18400	81696	1190	14164	1.266	0.575	1	0.11	24	2.71
16	-16	101000	448440	24000	106560	1570	15851	1.814	0.825	1	0.11	24	2.71

⁽¹⁾Based on bolt bending fatigue strength 180000 psi

⁽²⁾Based on bolt bending fatigue strength 127kg/mm².

⁽³⁾Shank limitation

Notes: For liner specifications or the following options:

- Stainless steel rod end body
- High temperature or high speed liners

Please see engineering section or contact RBC Aerospace Bearings.

Bearing configuration	Part number designations for a 0.2500 in. bore rod end	
Base P/N (no options)	FE4AN	M81935/5-4
Keyway on threads	FEK4AN	M81935/5-4K
Left hand thread	FEL4AN	M81935/5-4L
Deep key slot on base	FEW4AN	M81935/5-4W